

Brunetti[®]

Tube amplification

USER'S MANUAL

Matrix

Midi Multifunctions Looper/Switcher

Before using, please take few minutes to get familiar with your Amplifier and carefully read the advices, explanations hereby reported. All our units are hand made. For this reason you could find design or sound differences. All this as guarantee that you bought a true hand-made product.

Finest Italian handmade

CONGRATULATION FOR YOUR CHOICE!

Matrix is the only splitter - switcher that allows musicians to control their equipment.

Matrix is able to:

- Buffer the signal of your guitar.
- Insert in chain 3 low level loops. **Matrix** loops are totally transparent and clickless.
- Split your signal to 4 completely balanced and galvanically separated outputs, by a very high quality multiwindings transformer. Each output (A, B,C, TUNER) defines a system that allows you to use heads, pre and power amps, tuner.
- Control the effect loops of your heads and/or of your pre and power amps, and insert up to 2 rack multieffects in mono or stereo mode.
- Control the power outputs of your heads and/or of your power amps sending them to 1 stereo speaker cabinet or to 2 mono speaker cabinets.
- Connect automatically an internal load to the systems not in use to avoid damages to your equipment.
- Set speaker system in mono or stereo mode (mono heads or stereo power amps).
- Switch up to 3 functions for external outboard (channels, loops etc.)
- Supply phantom power to your foot pedal effects.
- Supply phantom power to your midi controller pedal, via a midi cable.
- Map the midi channels.

All these facilities are guaranteed by a new, fast and reliable microprocessor. Every component has been chosen for each own application. All the loops have been designed to allow the best performance with every kind of effects.

For all these reasons **Matrix** is unique in its kind. you can use it in all those situations a high switching ability is required, with no interferences and noise.

TECHNICAL SPECIFICATIONS

- Low noise transparent buffered HI/Z input
- 3 fast SSL lo/level loops, for foot pedal effects.
- 4 floating transformer balanced LO/Z outputs, with muting SSL (A, B, C, Tuner)
- 3 systems (A, B, C) for heads and/or pre and power amps
- 2 fast hi/level loops, for rack multieffects
- 3 NO or NC midi controlled switches
- 2 switchable speaker systems.
- 9 VdC / 200 mA phantom power for foot pedal effects
- 12VdC / 300mA phantom power for midi controller
- MIDI channels mapping (from 2 to 8 + omni)
- 1 Rack U- weight 2 Kg

EQUIPMENT

- Power cable
- Instruction manual
- Warranty Card

- 4 loop cables (1 stereo to 2 mono jacks).

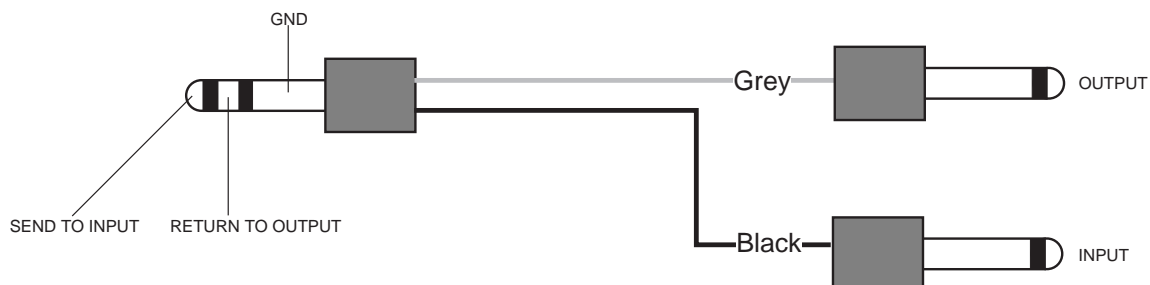

ELECTRIC CONNECTION

- Electric safety and correct work are guarantee when the unit is correctly earthed.
- Ensure that voltage value printed on the rear panel correspond to available current.

MATRIX FLOW DIAGRAM

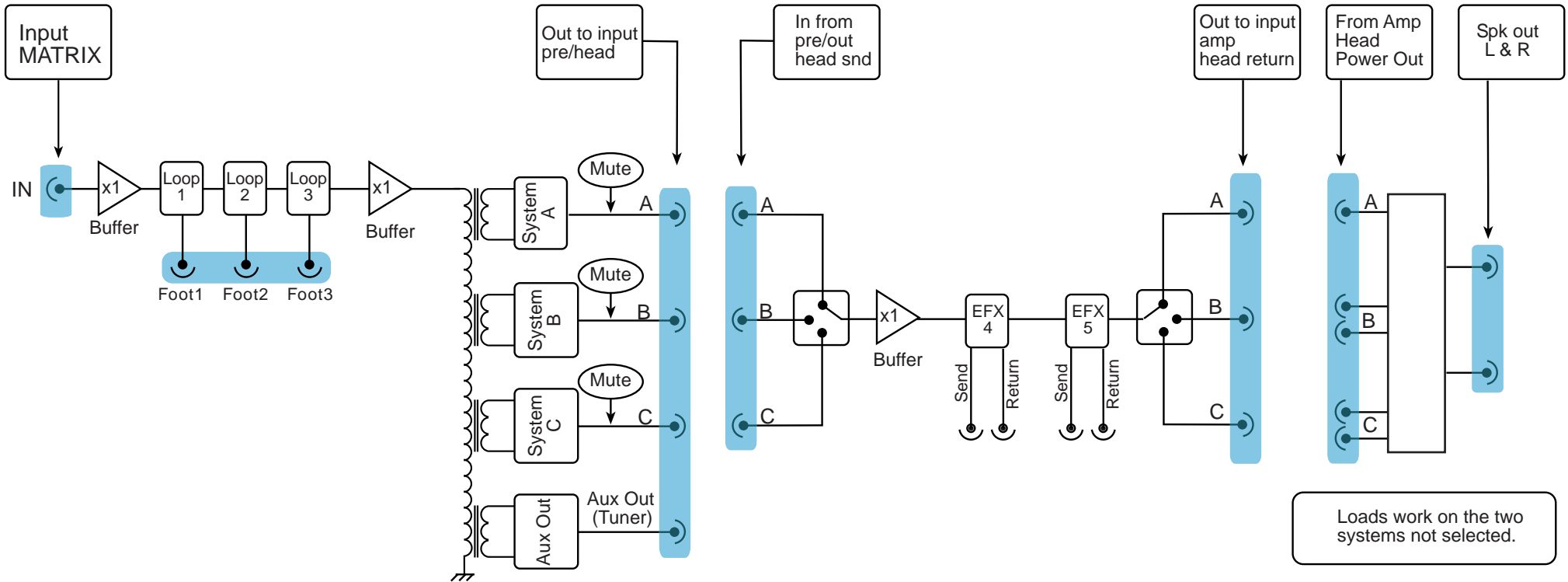

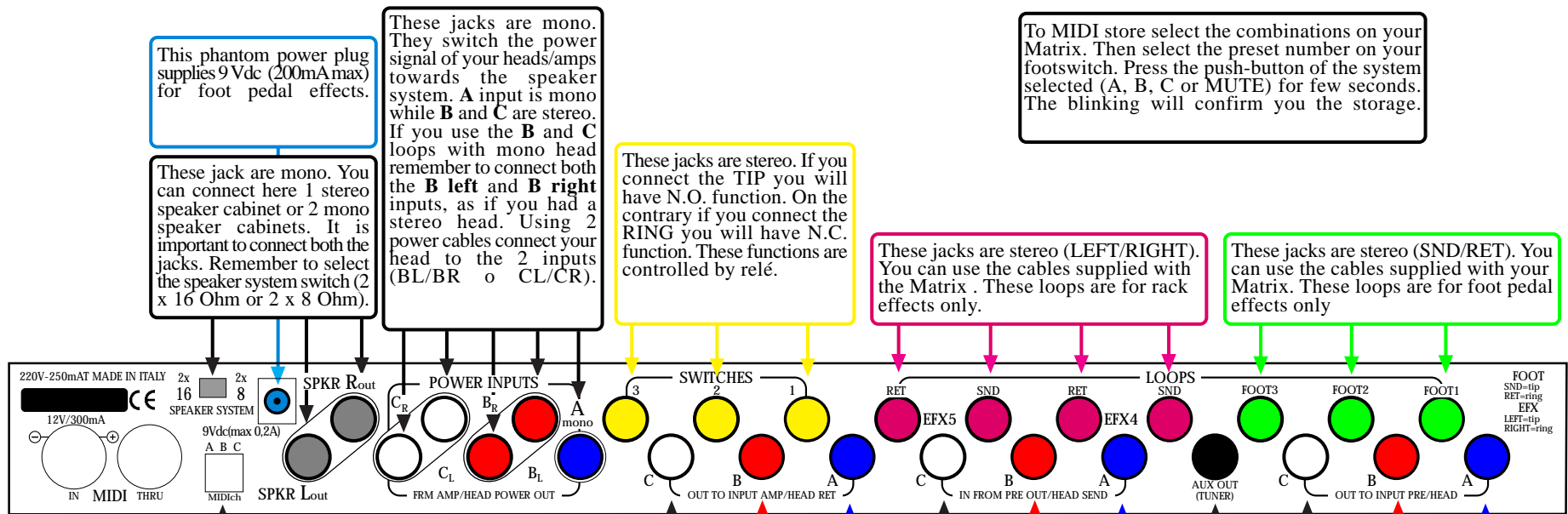
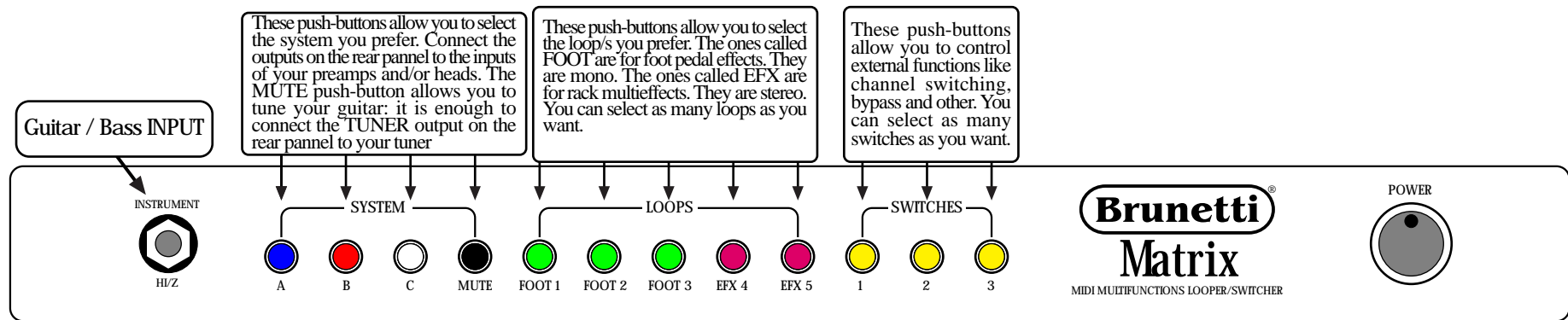

The MIDI ch dip switch allows you to select the receiving channel of program change. Here are the combinations :

	A	B	C
OMNI	off	off	off
2	on	off	off
3	off	on	off
4	on	on	off
5	off	off	on
6	on	off	on
7	off	on	on
8	on	on	on

The A jack is mono while B and C are stereo. You can use them to send the signal towards the RETURN of your head, or towards the INPUT of your stereo amps. Obviously the A system is mono so it is for heads only.

These jacks are mono. You can use them to receive the signal coming from the SEND of your heads, or coming from the MAIN of your power amps.

These jacks are mono. You can use them to send the signal of your guitar towards the different systems. The TUNER output is always active, so you can use it to tune your guitar or as a system.

Brunetti®

The following examples show you how to connect 2 heads, 1 foot pedal effect, 1 rack effect and 1 4x12" stereo speaker cabinet 8 ohm

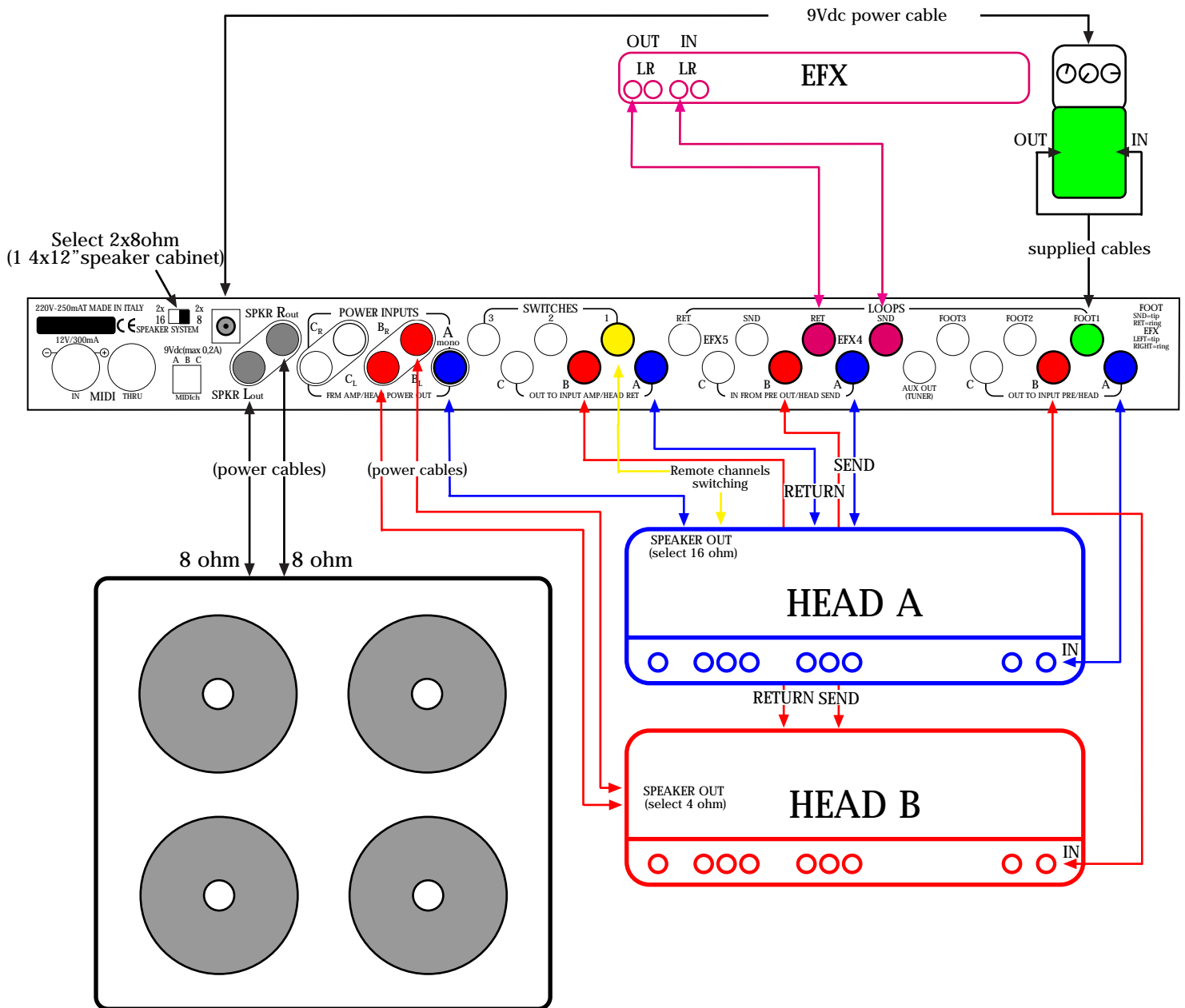

ATTENTION!!!

Where not written all the jack cables are mono. The power cables have to be of the correct size.

Remember to connect 2 cables to your 4 x 12" speaker cabinet and 2 cables to the B left and B right (or C left and C right) inputs. Use always all the POWER INPUTS (left and right) of the chosen systems (heads or power amplifiers).

Remember to select the speaker system switch on the rear panel: select 8 Ohm stereo for 1 4x12" speaker cabinet; select 16 Ohm for 2 1x12" speaker cabinets. It is very important to do that to avoid damages to your equipment.

Every doubt you have do not hesitate to contact us.

Brunetti®

The following examples show you how to connect 2 heads, 1 foot pedal effect, 1 rack effect and 2 1x12" speaker cabinets 16 Ohm

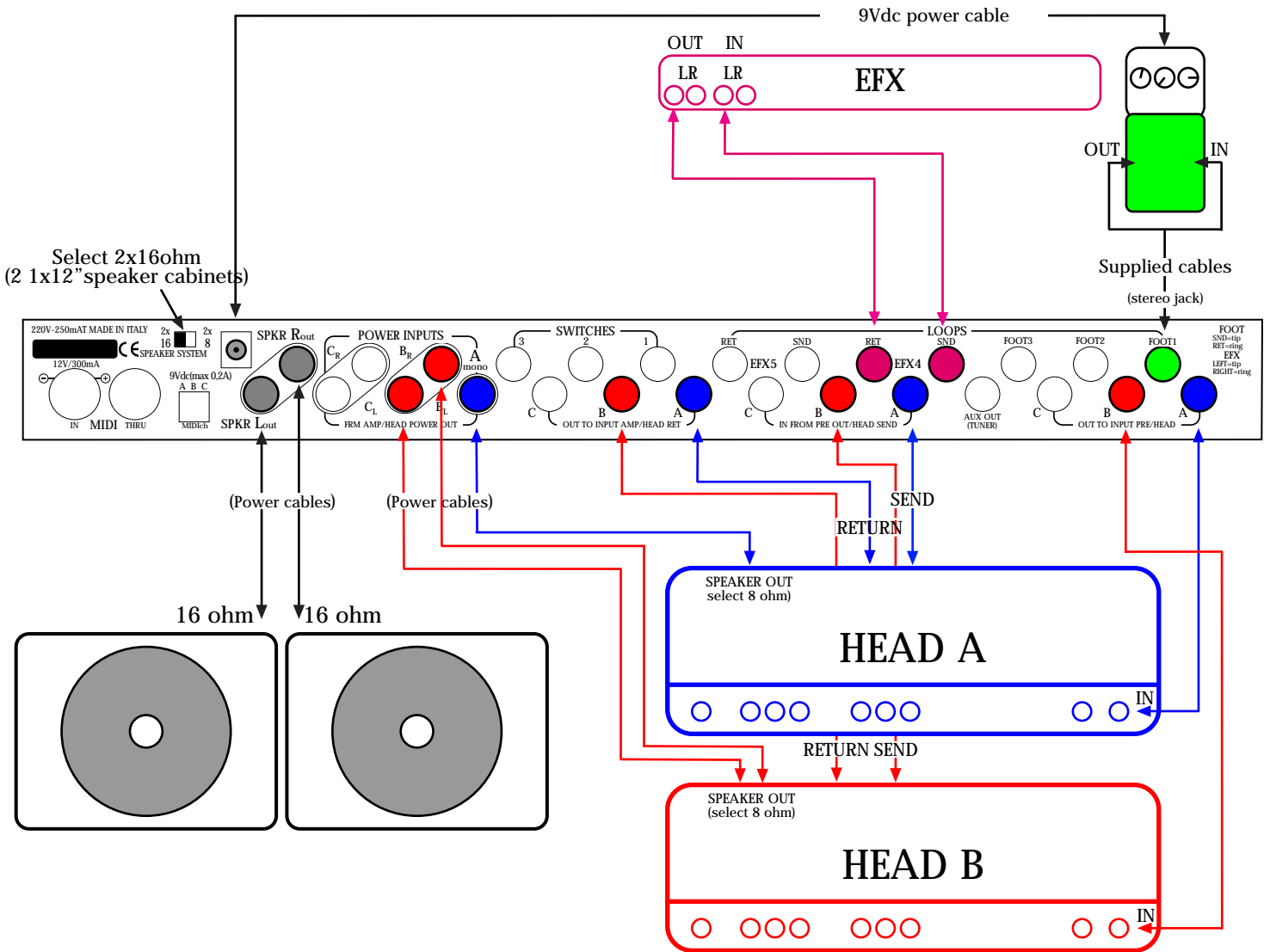

ATTENTION!!!

Where not written all the jack cables are mono. The power cables have to be of the correct size.

Remember to connect always 2 1x12" speaker cabinets even if your head is mono.

Use always all the POWER INPUTS (left and right) of the chosen systems (heads or power amplifiers).

Remember to select the speaker system switch on the rear panel: select 8 Ohm stereo for 1 4x12" speaker cabinet; select 16 Ohm for 2 1x12" speaker cabinets. It is very important to do that to avoid damages to your equipment.

Every doubt you have do not hesitate to contact us.

Brunetti®

The following examples show you how to connect 1 heads, 1 pre and power amp, 2 foot pedal effects, 1 rack effect and 1 4x12" stereo speaker cabinet 8 ohm

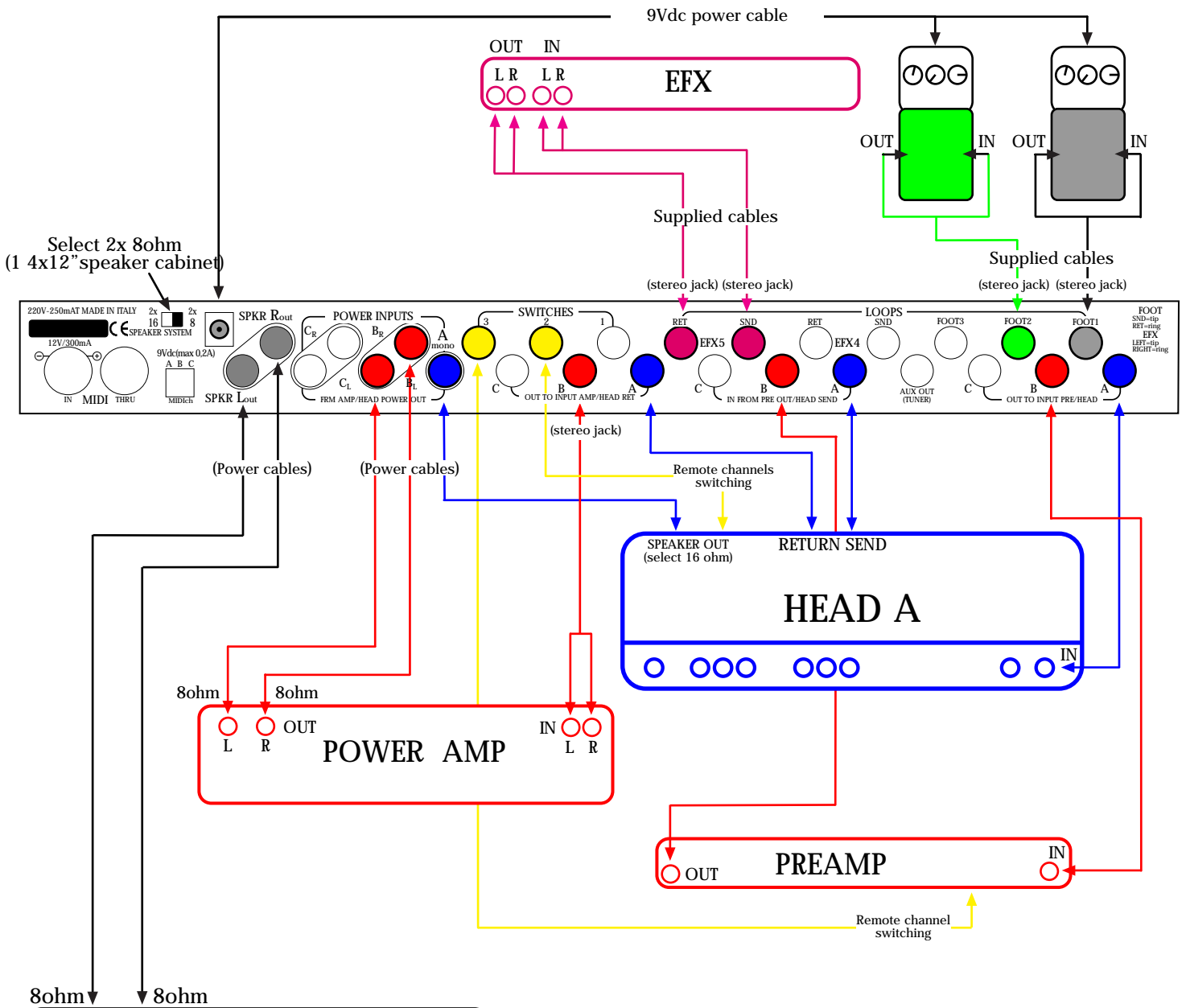

ATTENTION!!!

Where not written all the jack cables are mono. The power cables have to be the correct size.

Remember to connect 2 cables to your 4 x 12" speaker cabinet and 2 cables to the B left and B right (or C left and C right) inputs. Use always all the POWER INPUTS (left and right) of the chosen systems (heads or power amplifiers).

Remember to select the speaker system switch on the rear panel: select 8 Ohm stereo for 1 4x12" speaker cabinet; select 16 Ohm for 2 1x12" speaker cabinets. It is very important to do that to avoid damages to your equipment.

Every doubt you have do not hesitate to contact us.

Brunetti®

The following example show you how to connect 2 preamp, 1 poweramp, 2 footpedal efx, 1 rack efx, 1 stereo cabinet.

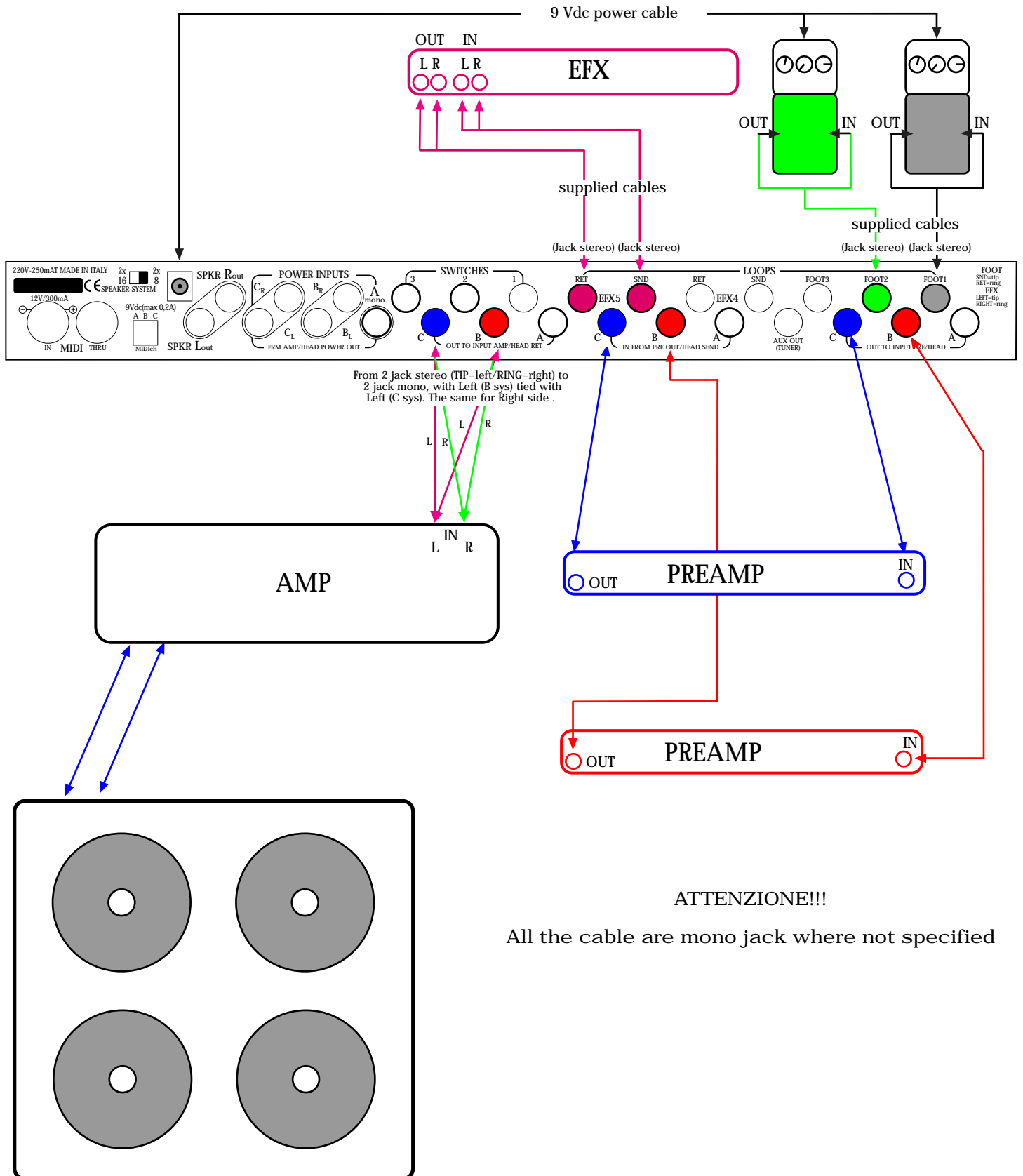

Brunetti®

The following example shows you how to connect 2 heads, 1 foot pedal effect, 1 rack effect and one speakers cabinet 16 Ohm.

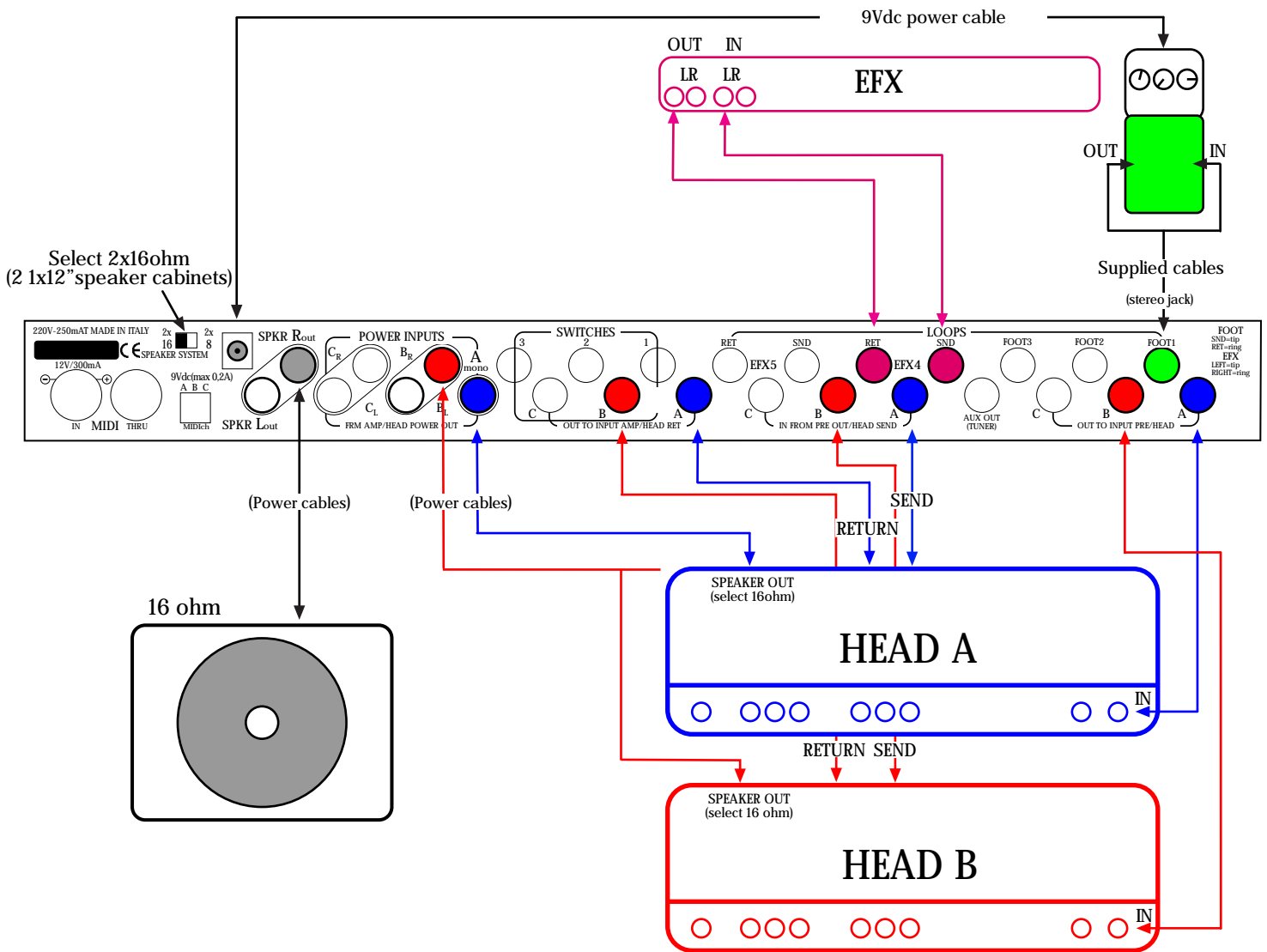

ATTENTION!!

Where not written all the jack cables are mono. The power cables have to be of the correct size. Remember to select the speaker system switch on the rear panel to "2x16ohm". Pls connect the power cables in the "B left" (or "C left") POWER INPUT. It is very important to do that to avoid damages to your equipment. Every doubt you have do not hesitate to contact us.

SYNTHESIS EFFECTS

The main characteristic of the synthesis effect (see example) is to modify the signal wave form. (i.e. the distortion effects).

This kind of effect should be used between the guitar and the input of your amp, in a standard connection chain.

MODULATION EFFECTS

The main characteristic of the modulation effect (see example) is to add and/or lay other wave forms to the signal. This kind of effect should be used in the loop effect of your amp, that is between the Preamp and the Power amp.

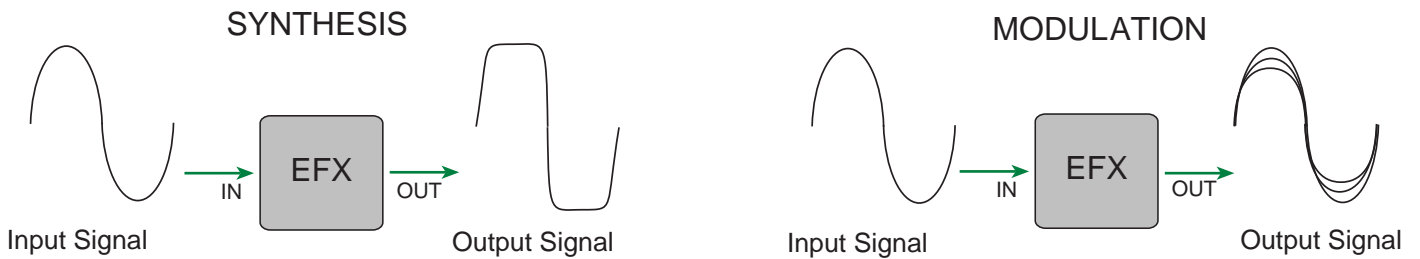

SERIAL LOOP

In a Serial Loop all the output signal coming from the Preamp passes through the effect. In this case on your effect unit it is necessary to adjust the balance between the DIRECT (DRY) and the EFFECT (WET).

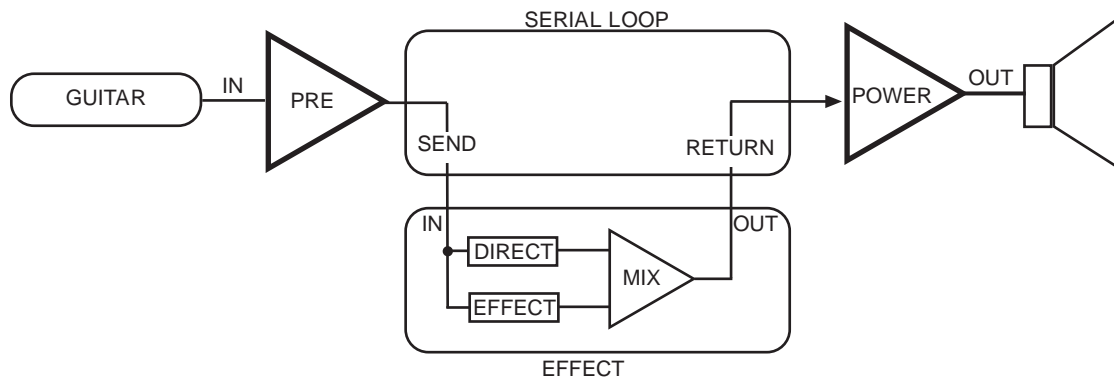

PARALLEL LOOP

In a Parallel Loop only a part of the direct sound passes through the loop effect, without going out from the Send. This part of the signal will be mixed with the signal that comes from the Return. In this connection the quality of the effect is not so important as it is in the Serial Loop connection, because the Direct will be kept by the loop (see drawing).

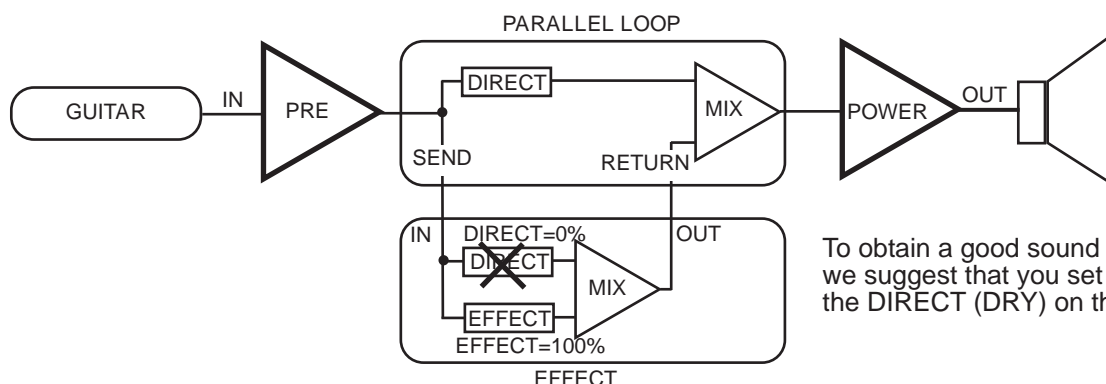

To obtain a good sound we suggest that you set on zero "0" the DIRECT (DRY) on the effect.

CLEANING

Before any kind of cleaning operation, disconnect the appliance from the electric supply.

- Do not throw water jets directly on the appliance.
- Do not use water steams to clean the appliance.
- Do not use solvents to clean the appliance.

Surface Cleaning: system suggested

Satin Aluminium: Soft cloth + product for metal parts

Stainless steel : Paper + product for chrome parts

WARNINGS

- The manufacturer declines all responsibility for any kind of damage to persons, things and/or animals resulting from a wrong use of the appliance.
- The appliance' s conformity is proved by CE symbol on the rear side.
- The manufacturer reserves the right to make any useful and essential change to the products without compromise the main safety and working features.
- Do not use the appliance barefoot.
- Do not touch the appliance with wet or moist hands or feet.
- Do not allow children or incompetents to use the appliance.
- Do not leave inflammable materials near to the appliance.
- Do not pull up the appliance by control knobs.
- Read carefully, compile and deliver the warranty attached to the appliance.
- The appliance' s repair may be done during the warranty period only by us, in our laboratory, or by authorized staff, in conformity to the national previsions in force.
- Control periodically all cables supplied with the appliance, if they result damaged, you have to replace them immediately with another one with the same characteristics.
- In case of damage contact the shop where you bought the appliance.
- The appliance must be earthed in conformity to the national previsions in force.

For any further information and/or support contact us.

Brunetti Marco & C. S.a.s

Via Dei Bonomini, 25/27

I - 41100 MODENA - ITALIA

Phone number : +39 059 / 243404

<http://www.brunetti.it>

e-mail : info@brunetti.it

e-mail : support@brunetti.it

commercial info

technical info